



**STRONG PARTNERS.  
TOUGH TRUCKS.™**

# R30XM<sub>3</sub> SERIES TECHNICAL GUIDE

[WWW.HYSTER.COM](http://WWW.HYSTER.COM)

# ➤ R30XM<sub>3</sub> DIMENSIONS

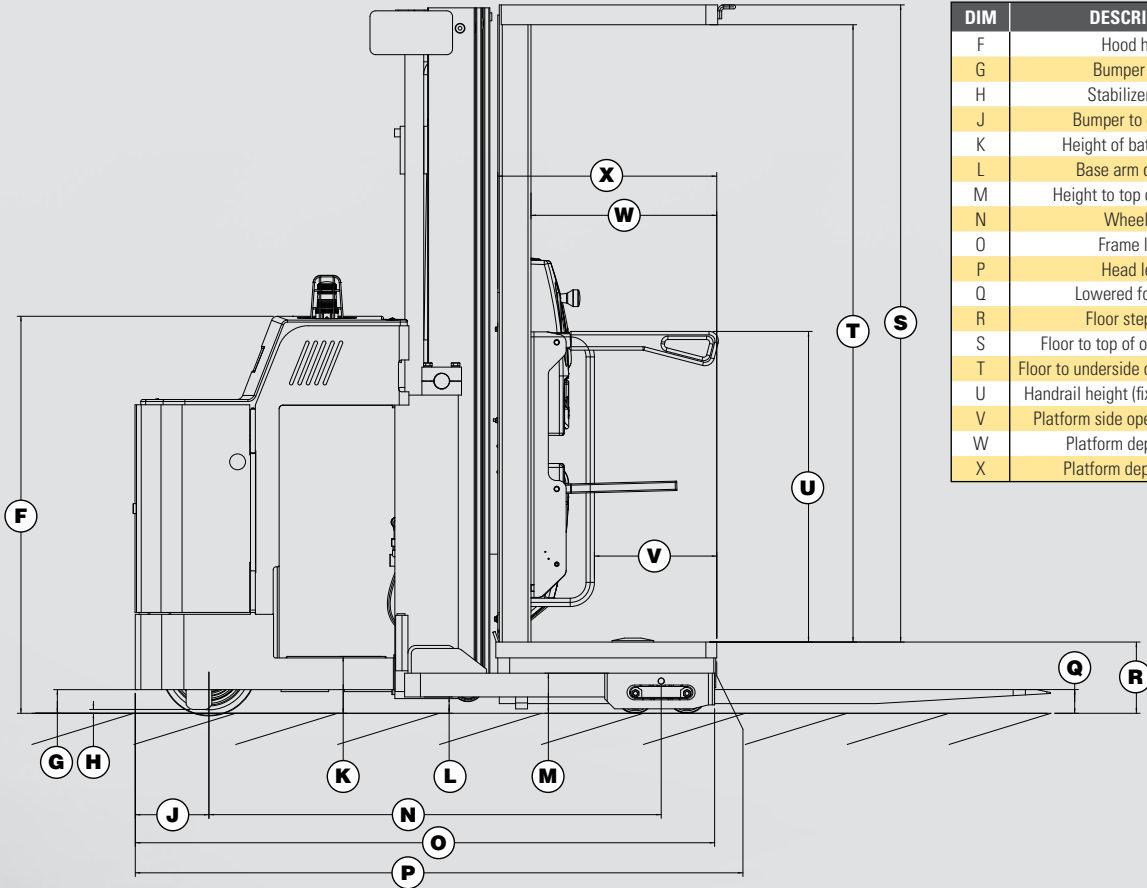

DIM	DESCRIPTION	VALUE IN (MM)
F	Hood height	50.0 (1270)
G	Bumper height	3.0 (76)
H	Stabilizer height	0.5 (12.3)
J	Bumper to drive axle	9.3 (236)
K	Height of battery rollers	7.2 (184)
L	Base arm clearance	2.1 (52)
M	Height to top of base arms	5.1 (129)
N	Wheelbase	57.1 (1450)
O	Frame length	73.1 (1856)
P	Head length	73.3 (1863)
Q	Lowered fork height	3.0 (76)
R	Floor step height	9.0 (228)
S	Floor to top of overhead guard	80.4 (2042)
T	Floor to underside of overhead guard	77.9 (1978)
U	Handrail height (fixed / retractable)	39.0 / 39.2 (990 / 995)
V	Platform side opening (fixed rail)	15.4 (392)
W	Platform depth (inside)	23.4 (595)
X	Platform depth (overall)	27.6 (702)

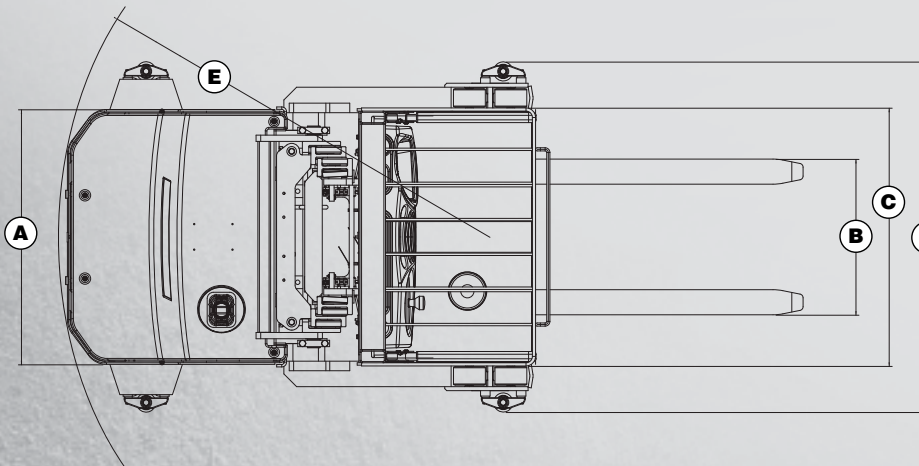

DIM	DESCRIPTION	VALUE IN (MM)
A	Frame width	40 (1016)
B	Fork spread	20.9 to 28.0 (530 to 711)
C	Platform width	40.2 (1022)
D	Overall width (w/o guide rollers)	40.7 (1035) / 48.3 (1227)
	Overall width (with guide rollers)	48.3 (1227) / 55.0 (1397)
E	Turning radius*	67.7 (1719)

\*Turning radius is the same with or without guide rollers

MAST PERFORMANCE				
	Lifting speed		Lowering speed	
	Empty	Rated load †	Empty	Rated load †
24V DC	67 ft/min (0.340 m/s)	45 ft/min (0.229 m/s)	80 ft/min (0.406 m/s)	80 ft/min (0.406 m/s)
36V DC	78 ft/min (0.396 m/s)	63 ft/min (0.320 m/s)	80 ft/min (0.406 m/s)	80 ft/min (0.406 m/s)
36V AC	85 ft/min (0.432 m/s)	60 ft/min (0.305 m/s)	80 ft/min (0.406 m/s)	80 ft/min (0.406 m/s)

† Rated load figures are based on 3000 lb. (1361 kg) load and a 24" load center.  
NOTE: Performance specifications are for truck with Standard Equipment. Performance specifications are affected by the condition of the vehicle and how it is equipped as well as the nature and condition of the operating area. If these specifications are critical, the proposed application should be discussed with your dealer.

MAST DIMENSIONS			
	Maximum fork height (TOF)	Overall lowered height	Overall extended height
	in (mm)	in (mm)	in (mm)
3-Stage (5.5')	195" (4953)	89" (2260)	282" (7162)
	213" (5410)	95" (2415)	300" (7620)
	240" (6096)	105" (2665)	327" (8306)
3-Stage (6.9')	276" (7010)	119" (3023)	363" (9220)
	300" (7620)	131" (3325)	387" (9830)

Lift heights over 360" (9144 mm) maximum fork height may require reduced capacity depending upon OEC dimensions.

# R30XM<sub>3</sub> SPECIFICATIONS

GENERAL				Hyster R30XM <sub>3</sub>	Hyster R30XM <sub>3</sub>
1	Manufacturer			Hyster	Hyster
2	Model designation			R30XM <sub>3</sub>	R30XM <sub>3</sub>
3	Power / voltage			Electric / 24 volts	Electric / 36 Volts
4	Operation type			Stand-up	Stand-up
5	Rated capacity		lb (kg)	3000 (1361)	3000 (1361)
6	Load center		in (mm)	24 (609)	24 (609)
7	Tire type, front / rear		load / drive	Poly / Poly	Poly / Poly
8	Wheels (X=driven)		front / rear	4 / (1X)	4 / (1X)
9	Mast – 2-Stage / 3-Stage (TOF)		in (mm)	See mast chart	See mast chart
10	Operator Clearance Height		in (mm)	77.9 (1978)	77.9 (1978)
11	Forks, Width / Thickness		in (mm)	4 / 1.8 (102 / 46)	4 / 1.8 (102 / 46)
12	Fork spread, inside to inside	Minimum / maximum	in (mm)	13 / 20 (330 / 508)	13 / 20 (330 / 508)
13	Fork spread, outside to outside	Minimum / maximum	in (mm)	21 / 28 (533 / 710)	21 / 28 (533 / 710)
14	Top of fork, mast lowered		in (mm)	3 (76)	3 (76)
15	Head length, length to face of operator deck	3-stage	in (mm)	73.3 (1863)	73.3 (1863)
16	Base width 41" / width across guide rollers		in (mm)	40.7 / 48.3 (1035 / 1227)	40.7 / 48.3 (1035 / 1227)
17	Base width 48" / width across guide rollers		in (mm)	48.3 / 55 (1227 / 1397)	48.3 / 55 (1227 / 1397)
18	Height, standard 3 stage mast lowered		in (mm)	89 (2261)	89 (2261)
19	Operator platform size	Width / depth	in (mm)	40 / 27.5 (1016 / 698)	40 / 27.5 (1016 / 698)
20	Turning radius, minimum outside		in (mm)	67.7 (1719)	67.7 (1719)
21	Stacking aisle, zero clearance	5.5" 3-stage mast	in (mm)	122.7 (3116)	122.7 (3116)
22	Intersecting aisle, equal aisles 40" x 48" pallet	Standard mast	in (mm)	70.1 (1780)	70.1 (1780)
23	Stability, comply with ANSI?			YES	YES
24	Travel speed *	NL / RL	mph (km/h)	6.5 / 6.5 (10.5 / 10.5)	6.5 / 6.5 (10.5 / 10.5)
25	Lift speed	NL / RL	ft/min	See performance chart	See performance chart
26	Lower speed	NL / RL	ft/min	See performance chart	See performance chart
27	Truck weight	Without battery	NL	3845 (1744)	3845 (1744)
28	Axle loading - drive	Static with max. wt. battery	NL / RL	3338 / 2321 (1514 / 1053)	3338 / 2321 (1514 / 1053)
29	Axle loading - load wheels	Static with max. wt. battery	NL / RL	2407 / 6422 (1092 / 2913)	2407 / 6422 (1092 / 2913)
30	Tire size, drive		in (mm)	12 / 5.5 (305 / 140)	12 / 5.5 (305 / 140)
31	Tire size, loadwheel		in (mm)	5.0 / 3.0 (127 / 76)	5.0 / 3.0 (127 / 76)
32	Wheelbase		in (mm)	57.1 (1450)	57.1 (1450)
33	Ground clearance	No load , lowest point	in (mm)	0.6 (14)	0.6 (14)
34	Ground clearance	No load , center wheelbase	in (mm)	1.9 (47)	1.9 (47)
35	Brakes, Method of control	Service / parking		Foot	Foot
36	Brakes, Method of operation	Service / parking		Spring applied / electric released	Spring applied / electric released
37	Battery	Type		Lead acid	Lead acid
38				24	36
39			lb. (kg)	1600 (726)	1600 (726)
40	Traction motor control method			AC transistor	AC transistor
41	Pump motor control method			Contacttor	Contacttor
42	Number of travel speeds			Infinitely variable	Infinitely variable

Right Angle Stack and Equal Intersecting Aisle dimensions provided with a 40" wide x 48" long pallet load, allowing zero clearance.

\*Speeds are the same in either direction, with or without rated load. Steer angle <10 degrees.

**CERTIFICATION:** These Hyster® lift trucks meet design specifications of Part II ANSI B56.1-1969, as required by OSHA Section 1910.178(a)(2) and also comply with Part III ANSI B56.1-revision in effect at time of manufacture. Certification of compliance with the applicable ANSI standards appears on the lift truck. Performance specifications are for a truck equipped as described under Standard Equipment on this Technical Guide. Performance specifications are affected by the condition of the vehicle and how it is equipped, as well as by the nature, condition of the operating area, proper service and maintenance of the vehicle. If these specifications are critical, the proposed application should be discussed with your dealer.

BATTERY SPECIFICATIONS							
Number of cells	Cell size	Plates per cell	Capacity 6 hr rate amp hr (kwh)	Battery dimensions			Weight lb (kg)
				"X" (width)	"Y" (length)	"Z" (height)	
				in (mm)	in (mm)	in (mm)	
12	125	17	1000 (23.4)	38.1 (969)	13.5 (342)	30.6 (776)	1818 (825)
12	140	17	1120 (26.2)	38.1 (969)	13.5 (342)	30.6 (776)	1851 (840)
12	155	17	1240 (29.0)	38.1 (969)	13.5 (342)	30.6 (776)	1860 (844)
18	125	11	625 (21.9)	38.1 (967)	13.3 (339)	30.6 (776)	1800 (816)
18	140	11	700 (24.6)	38.1 (967)	13.3 (339)	30.6 (776)	1849 (839)
18	155	11	775 (27.2)	38.1 (967)	13.3 (339)	30.6 (776)	1859 (843)

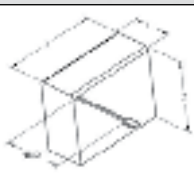

Battery Compartment Length is measured from front to rear. Battery Compartment Width is measured across truck. SB350 Amp "Red" Connector, Cable Position B, Cable Length 16" (405mm). Maximum Cable Gauge 1/0 AWG. Battery with lid will NOT fit in battery compartment. Battery Weight Range 1600 - 1900 lbs. Amp Hour Capacity Min / Max - 24 volt truck 960 / 1240. 36 volt truck 600 / 775.

TRAVEL SPEEDS (24V)		
Fork height in (mm)	Steer angle <10° mph (kph)	Steer angle >10° mph (kph)
0 (0)	6.5 (10.5)	6.5 (10.5)
24 (610)	6.5 (10.5)	3.0 (4.8)
60 (1524)	6.0 (9.7)	2.6 (4.2)
116 (2946)	4.2 (6.7)	2.0 (3.2)
150 (3810)	3.0 (4.9)	1.6 (2.6)
195 (4953)	1.6 (2.6)	1.2 (1.9)
212 (5385)	1.0 (1.6)	1.0 (1.6)
>212 (5385)	No travel*	No travel*

Note: Speed limits are for trucks at operating temperature with fully charged battery. Speeds are the same in either direction, with or without rated load.

For lift heights between 24.0" (610 mm) and 212.0" (5385 mm), traction speed is reduced when steering angle exceeds 10°.

\* Travel above 212.0" (5385 mm) fork height requires a High level traction option. Capacity reduction required.

Contact your local dealer for additional information.

# STANDARD FEATURES AND OPTIONS

## STANDARD EQUIPMENT

- 195" MFH / 89" OALH 3-stage anti-rattle mast
- 40.0" wide x 27.5" deep operator platform
- 42.0" X 1.75" X 4.0" standard taper pin type forks
- 12.0" X 5.5" black polyurethane drive tire
- 5.0" X 3.0" articulating tandem - high load compound load wheel
- 39.0" L x 14.6" W x 31.5" H battery compartment
- 24 volt AC electrical system
- Standard application / environmental construction
- 41" outside dimension (base width) basearms
- UL classification type "E"
- Key switch start
- Return to center steering
- Ergonomically advanced multi-function control handle with rotational adjustment and single speed lift/lower
- Electric park brake - automatically engaged / foot released
- Heavy duty pallet clamp - automatically engaged / foot released
- AC transistor control
- AC traction motor
- Single hydraulic pump and motor
- Controller area network (CANbus) communications
- On demand electric power steering
- AC steer motor
- Auto deceleration system (ADS) with regenerative braking
- Graphic LCD multi-function smart display with back lighting
  - Hour meters; truck, traction and hoist pump
  - Bar graphic battery discharge indicator
  - Low battery lift interrupt
  - Performance mode selection and indication
  - LED status indicators with symbols
  - 4 operator selectable, programmable performance modes
  - User passwords and operator logs with history
  - Steer wheel angle graphic indication
  - Truck inspection check list
  - Truck speed indication in mph or KPH
- Cantilever style overhead guard
- Wire mesh screen operator guard
- Amber LED strobe - continuous operation with key-on
- Hysense continuous height sensing
- Slack chain indication
- Shock dampening operator's compartment floor mat
- Battery power disconnect button
- Operator convenience station with storage areas, trash bin, beverage & clipboard holders
- Full body harness and operator tether
- Battery compartment corrosive resistant steel rollers
- Retractable platform side gates with cushioning and lift / traction cutout interlock
- Electric horn
- Static discharge strap
- Operating manual and labels – English
- 12 month / unlimited hours full truck warranty
- 3 years/ 6,000 hour powertrain warranty
- Lifetime frame warranty

## OPTIONAL EQUIPMENT

- 36 Volt electrical system
- 175 Amp gray, position B - 16" lead length
- Battery spacer group
- Battery stand
- Battery puller
- AC transistorized hydraulic control
- UL classification type "EE"
- Application / environmental construction
  - Cooler/freezer package - operating temperatures: 0° F to +120° F
  - Subzero freezer package - operating temperatures range: -20° to +120° F
- 48" Outside dimension (base width) basearms
- Operator platform
  - 27.5" deep x 48" wide
  - 27.5" deep x 54" wide
  - 27.5" deep x 60" wide
- Safety glass shield
- Fixed hoop side rails
- 6" vertical adjustable operator console
- Retractable operator tether with full body harness or medium body belt
- Heavy duty automatic pallet clamp with opening range from 1/2" to 6"
- Keyless - toggle switch
- Various mast options available
- Various fork options available - 36"-78" long standard taper pin type forks
- Lift limit without push button override
- Lift limit with push button override
- Lowering limit with push button override
- High level traction above 212" with restricted steer
- Drive tire
  - Polyurethane - red diagonal grooved (92 durometer) press-on
  - Polyurethane - cream vulkollan (94 durometer) press-on
- Various guidance systems
  - Side guide rollers
  - Wire guidance
  - Line driver
- Various light packages
  - Dome light and 2 speed fan package mounted on top of overhead guard
  - Dome light, 2 speed fan and halogen glass lens spot light package
  - Dome light, 2 speed fan and led plastic lens spot light package
  - 2 Led plastic lens spot lights mounted under overhead guard
- DC to DC converter - 25 amps / 300 watts @ 12 volts
- Multi-turn steering
- Audible alarms self adjusting 82-102 db(A)
  - Back-up alarm - reverse direction activation
  - Motion alarm - forward and reverse direction activation
  - Motion alarm - continuous operation with key-on
- 2 speed upper body fan - console mounted
- Parts manual - printed or CD



Hyster Company  
P.O. Box 7006  
Greenville, North Carolina  
27835-7006  
Part No. R30XM3/TG  
10/2016 Litho in U.S.A.

Visit us online at [www.hyster.com](http://www.hyster.com) or call us at **1-800-HYSTER-1**.

Hyster, , and STRONG PARTNERS. TOUGH TRUCKS. and MONOTROL are registered trademarks in the United States and certain other jurisdictions. Hyster products are subject to change without notice.

All trucks shown with optional equipment. © 2016 Hyster Company. All rights reserved.